

A cost-efficient, robust solution that gives you the benefit of high productivity and savings

The IN Series is a well proven design and an efficient pulse-jet cleaning system. Insertable (IN) Jet Pulse filters are modular bag filters in which the dust-laden air enters through the base and is evenly distributed between the filter bags. This ensures a smooth flow of both coarse and fine particles into the filter.

Benefits

Efficiency

- The pulse jet system automatically cleans the bags row-by-row even as the dust is being filtered. The advantage is that the filter continues to work while the bags are being cleaned.

Savings

- Being a low maintenance solution, the IN needs minimum downtime. This means continuous plant operations for you.
- The filter control system helps maintain a low pressure drop – helping you save both compressed air and energy.
- The filter module comes in three sizes: 24, 36 and 54 cylindrical bags mounted on wire cages 1.5 m in length and 127 mm in diameter.

Flexibility

- You can separate almost any kind of dust – fine, or abrasive.



Features

- Capacity: 500 – 4.500 m³/h
- Filter size: 13.1 – 29.7 m² filter surface
- Standard 4.5% vacuum (450 mmWC)

Subject to alterations

Dimensioning:

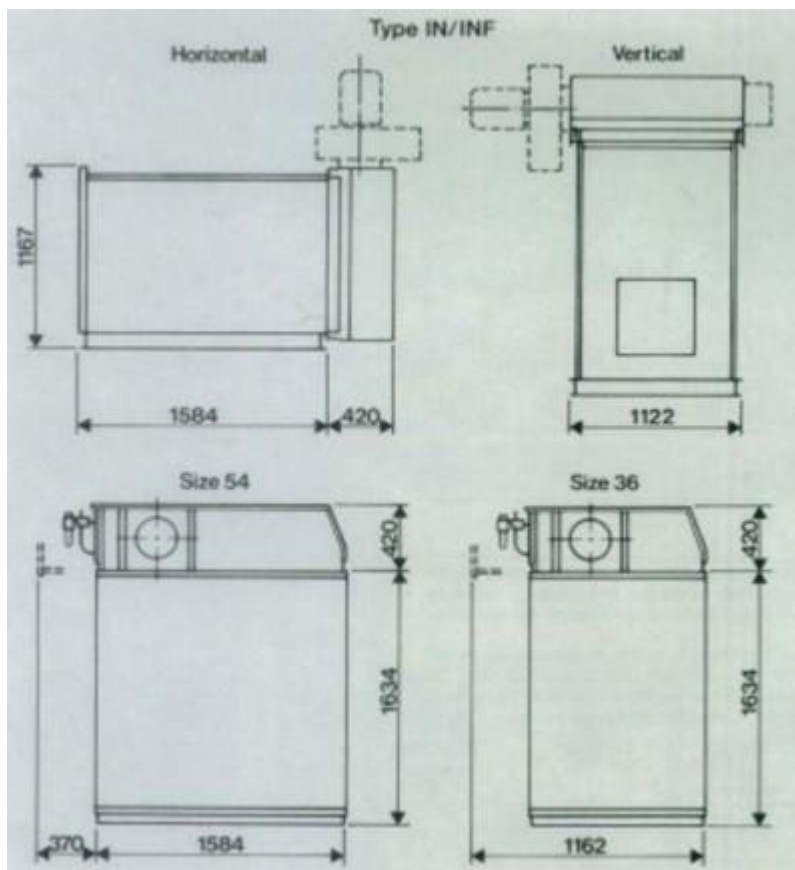
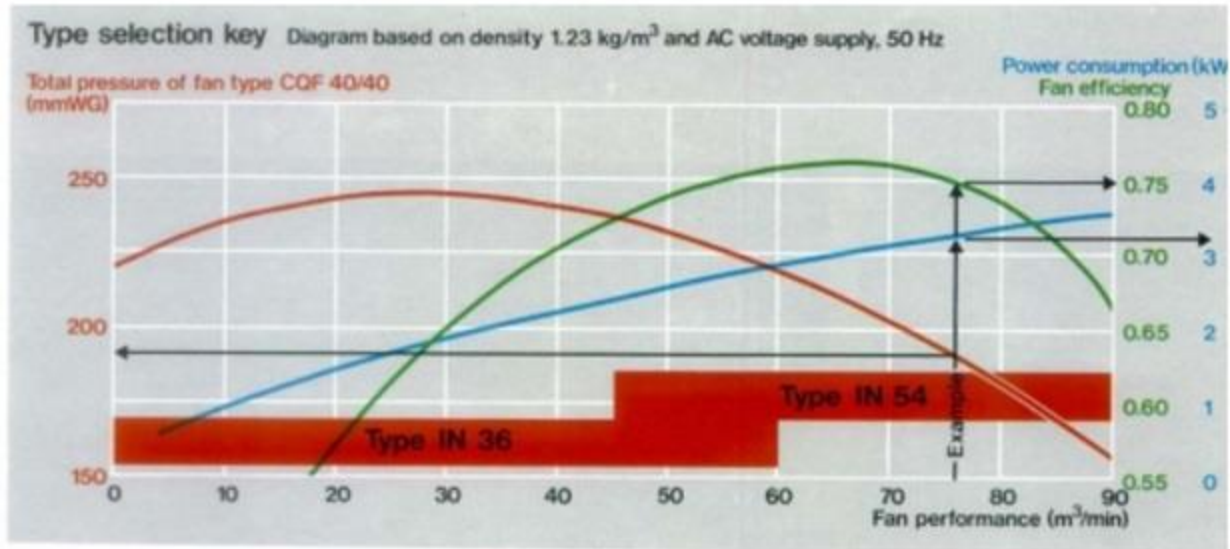

Example:

A material conveyor to be dedusted at an air temperature below 80°C at a rate of 75 m³/min.

Solution:

Insertable Jet Pulse Filter type INF 54 is recommended.

The CQF 40/40 fan will work at an efficiency of 0.75 with at total pressure of 180 mm WG and with a power consumption of 3.2 kW.

For temperatures between 80°C and 200°C an insertable Jet Pulse Filter, type IN 54 with special bags and separate fan is recommended.

For larger filter sizes, please contact Simatek's sales department.

Industries we serve for emission control and product recovery (detailed industry segments on our homepage)

- Cement & Lime
- Grain & Feed
- Energy & Waste
- Food & Dairy
- Speciality Powder
- Chemical & Mineral resources